

General Information	02
After-sales Service	02
Specifications	03
Identification of Parts (AC Side)	04
Identification of Parts (DC Side)	05
Included Components	06
Important Safety Instructions	07
General Safety Information	07
Electric Safety	07
Installation Safety	08
Placement Requirements	08
DC Side Connection Requirements	09
Battery Bank Requirements	10
Grounding Requirements	11
Operation Safety	11
Use Safety	12
Protection Descriptions	13
Troubleshooting	14

The DOD Pure Sine Wave Power Inverter delivers outstanding performance for back-up power and off-grid system, which is widely used in emergencies or household. The advanced pure sine wave technology provide cleaner, smoother and more reliable power for sensitive equipment without any interference. Brilliant design using top electronic materials makes it safe, stable with long machine-life.

■ Pure Sine Wave

The DOD power inverter output a pure sine wave waveform, which has the same quality as utility or domestic power. This smooth pure sine wave allows you to operate sensitive electronic devices that require a high quality waveform with little harmonic distortion. Almost any electronic device could be powered using **DOD PURE SINE WAVE INVERTER**.

DOD pure sine wave inverter is more efficient (high efficiency 90%) which able to use less energy and allow more devices to be used. More energy savings from low no-load losses. Superb load shock resistance will not harming your equipment when running.

■ Soft Start Technology

Thyristor soft start technology included can effectively reduce the starting inrush current of the inverter, reduce the impact on the power grid, improve the quality of power and the appliance life. Overall, it improve the stability and reliability of the system which is especially necessary for equipment that has an inductive load or electrical motor. To better protect the machine, you'd better turn on the switch of the appliance first before starting the inverter.

AFTER-SALES SERVICE

Dear user:

DOD adheres to the principle of comprehensive, high quality and fast service. Taking your satisfaction as the highest goal, we provide you with the following services:

1. Free 2-year warranty for the DOD pure sine wave power inverter.
2. All feedback on the quality and use of the product will be replied to within 24 hours. And we will determine the measures to deal with the actual situation based on your feedback.
3. In the case of quality problems under normal use, please contact us as soon as possible to facilitate the timely repair and replacement of your products.
4. If any problems with products that are out of warranty, please contact us and we will try our best to assist you in solving the problem.
5. The following situations are not covered by the warranty:
 - a. Self-disassembly products
 - b. Unauthorized repair, misuse and modification.
 - c. Damaged by abnormal voltage, fire, liquid and other external causes
 - d. Abnormal storage conditions like overheating, humidity.
 - e. Damage due to reverse polarity.

6. DOD E-mail Address: jxkgz2021@163.com

Model	1000 Watts	2000 Watts	4000 Watts	5000 Watts
Rated Input Voltage	12VDC	12VDC	12VDC /24VDC	12VDC
Continuous Power	1000W	2000W	4000W	5000W
Peak Power	2000W	4000W	8000W	10000W
Input Voltage Range	9.5-16VDC	9.5-16VDC	9.5-16VDC /19-32VDC	9.5-16VDC
Over Voltage Shutdown	16VDC 9.5VDC	16VDC	16VDC /32VDC	16VDC
Low Voltage Shutdown	10VDC	9.5VDC	9.5VDC /19VDC	9.5VDC
Low Voltage Alarm	0.8A	10VDC	10VDC /20VDC	10VDC
No Load Current	1100W	0.6-0.9A	0.6-0.9A	0.9-1.1A
Over Load Protection	□110 / □120V	2500W	4200W	5200W
Output Voltage	AC±10%(Refer to label)			
Frequency	□60Hz ±1Hz			
Wave Form	Pure Sine Wave			
Efficiency	≥ 90%			
Over Heat Protection	149°F±8°F			
Short Circuit Protection	Yes			
Display	LCD			
USB	5VDC, 0-2.4A × 2 MAX 3.4A			
Type-C	Max 18W (5V / 3.1A, 7V / 2.4A, 9V / 2A, 12V / 1.5A)			
Cooling Fan	Thermal controlled cooling fan. It works only when the inverter housing temperature reaches 113°F.			
Operating Temperature (Automatic Recovery/ Shutdown)	32-113°F			
Storage Temperature	14-113°F			

IDENTIFICATION OF PARTS(AC SIDE)

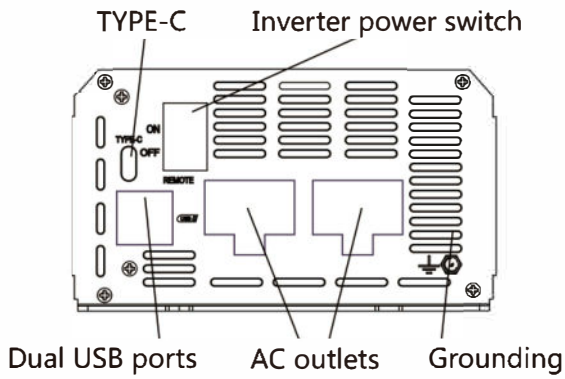

1000 Watts

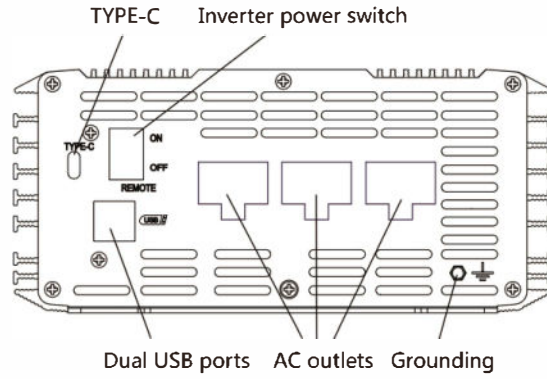

2000 Watts

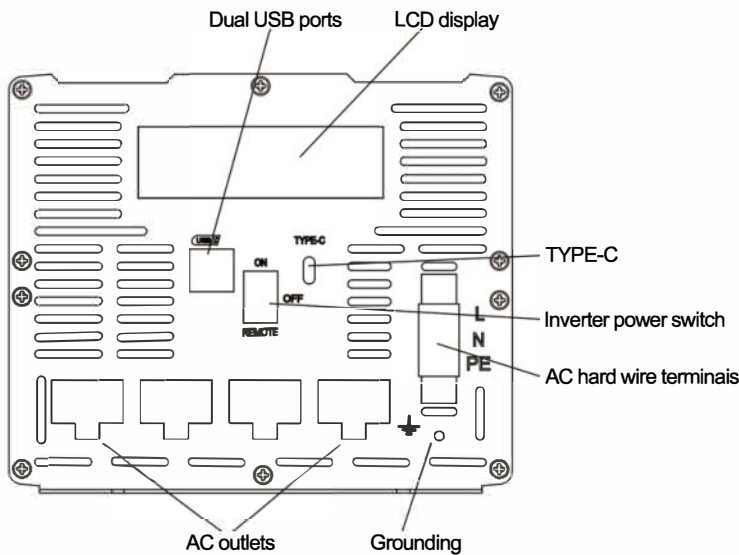

4000 Watts

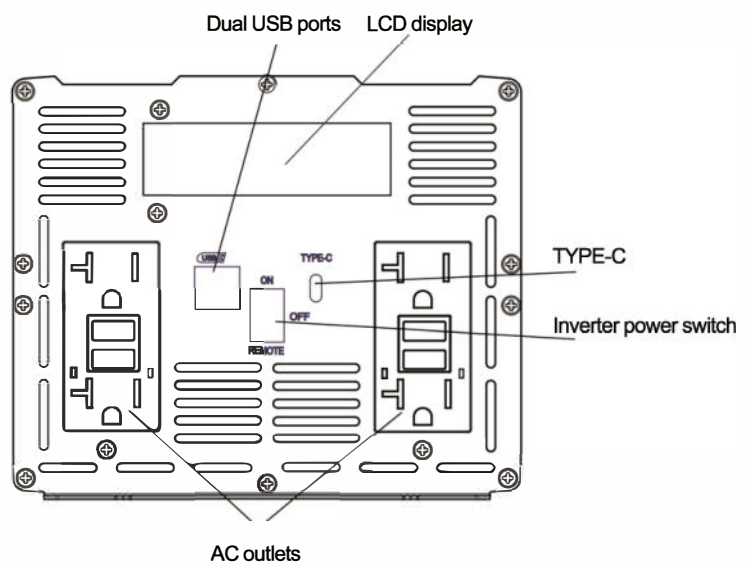

5000 Watts

Key Parts

- 1. USB Power Port × 2** 5V / 2.4A for charging tablets, and other small electronic devices.
- 2. Type-C Port × 1** — Max 18W (5V / 3.1A, 7V / 2.4A, 9V / 2A, 12V / 1.5A)

3.

	1000 Watts	2000 Watts	4000 Watts	5000 Watts
AC sockets	2	3	4	4
Single socket current	Max 15A	Max 15A	Max 15A	Max 20A
Output Voltage	120V±10%			
Single Socket Power	< 1100W	< 1800W	< 2000W	< 3000W

- 4. **ON/OFF/REMOTE Switch** - Under proper operation, the indicator will light up red when the ON/OFF button is pressed.
- 5. **Ground Terminal** — This is for connecting the chassis and insulated safety ground wire of the power inverter.
- 6. **LCD Display** — While inverter working, the LCD display will show Battery Status Level, Input Voltage, Output Voltage, Hertz, Load Wattage. In case of a malfunction, it will show Warning Indication.

Once the inverter is on protection mode, the following codes will shown:

- a. **UNDERVOLTAGE:** Under-voltage Protection
- b. **OVERVOLTAGE:** Over-voltage Protection
- c. **OVERLOAD:** Over-load or Short-circuit Protection
- d. **OVERHEAT:** Overheating protection

IDENTIFICATION OF PARTS(DC SIDE)

DC input connector(-) DC input connector(+)

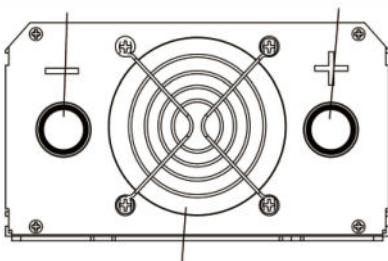

Thermal control cooling fan

Thermal control cooling fan

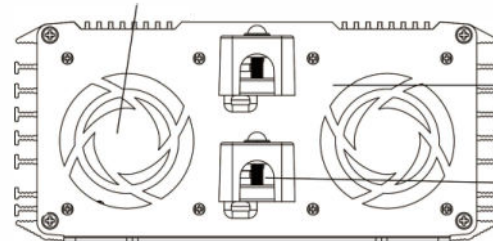

DC input connector(+)

DC input connector(-)

Thermal control cooling fan

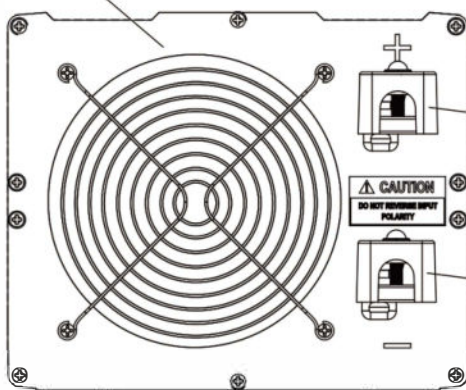

DC input connector(+)

DC input connector(-)

Thermal control cooling fan

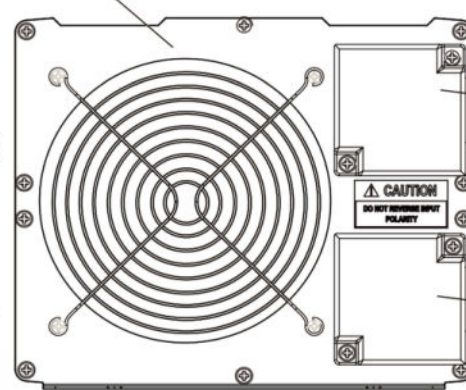

DC input connector(+)

DC input connector(-)

INCLUDED COMPONENTS

DOD	1000 Watts	2000 Watts	4000 Watts	5000 Watts
Wireless Remote Control	1	1	1	1
Inverter Cable	2	2	2	4
Earth wire	1	1	1	1
Wrench	1	1	1	1
Fuses	2	6	6	6

Wireless Remote Control

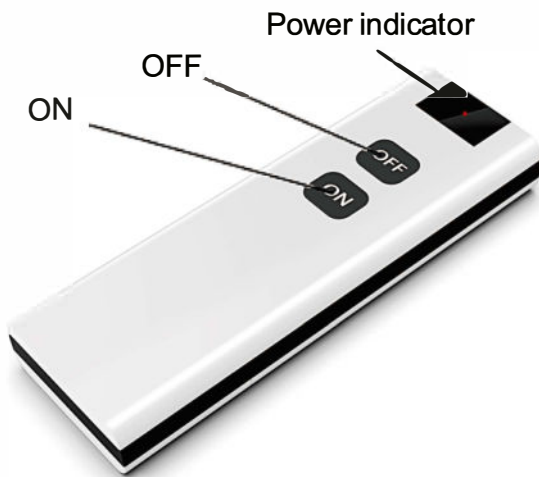

As the package comes without battery, you have to prepare 23A battery for the use of the Remote. It has 3 areas from top to bottom, which are power indicator, OFF button, and ON button.

Pre-designed 4 Screw Hole Locations

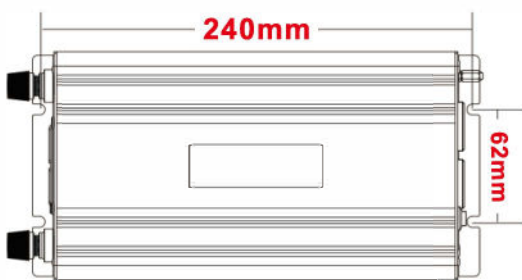

1000 Watts

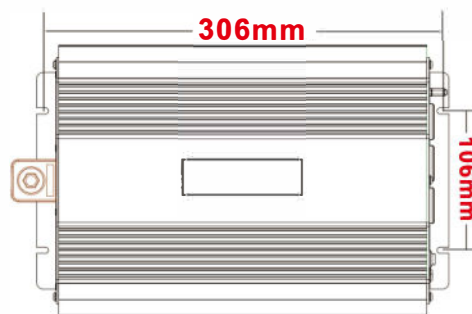

2000 Watts

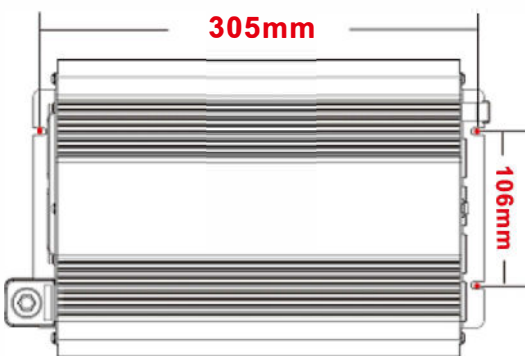

4000 Watts

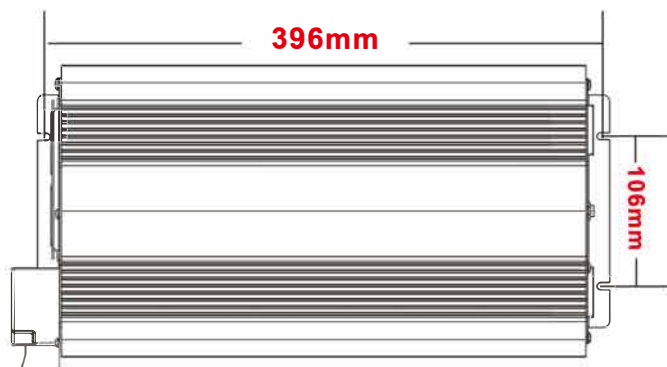

5000 Watts

Please read these instructions carefully.

In order that you can better use this inverter and prevent accidents of personal injury and object damage, please focus on the contents of the safety precautionary points and use common sense in life to operate the inverter carefully.

This manual contains important safety, installation and operating instructions for the inverter. Please be sure to read and comply with the following symbols in this manual:

ⓘ Indicates what must be performed

⊘ Indicates prohibited operations

Ⓢ Indicates what must be performed

■ General Safety Information

- ⊘ NEVER disassemble or attempt to repair the inverter without the guidance of a professional DOD service team staff.
- ⓘ Installation and wiring must comply with the Local and National Electric Codes (NEC) and must be done by a certified technician.
- ⓘ Read all of the instructions and cautions in the manual before beginning the installation..
- ⓘ Make sure all connections going into and from the inverter are tight. There may be sparks when making connections, therefore, make sure there are not flammable materials or gases near installation.

■ Electric Safety

WARNING

- ⊘ NEVER connect the AC output of the unit directly to an Electrical Breaker Panel/ Load Centre which is also fed from the utility power / generator.
- ⊘ NEVER use with positive ground electrical systems. The unit is designed to be used with a negative ground electrical system!
- ⓘ Make sure the inverter is off before connecting anything.
- ⓘ When connecting battery terminals, ensure the polarity of the battery connections is correct. Incorrect polarity may cause permanent damage to the unit.
- ⓘ ALWAYS make sure inverter is in OFF position and disconnect all AC and DC connecting when working on any circuit associated with the inverter.
- ⓘ Be careful when touching bare terminals of capacitors as they may retain high lethal voltages even after power is removed.

■ Installation Safety

1.Placement Requirements

Make sure there is enough space and that the installation is done according to the guidelines

WARNING

- ⊘ NEVER install the inverter in a sealed enclosure with flooded batteries. Gas can accumulate and there is a risk of explosion.
- ⊘ NEVER mount the inverter vertically on a vertical surface since it would present a hazard for the fan opening which will affect your inverter's life and even causing other dangers.
- ⊘ NEVER mount the inverter upside down.
- ⓘ **DOD** Inverter should be placed in a horizontal position.
- ⓘ **Well-ventilated area** — Allow at least 12 inches of clearance around the inverter to keep objects from blocking the vents and to provide adequate air circulation.
- ⓘ **Dry** —No liquids are allowed near the inverter. It should be in a place where there is no moisture of any kind.
- ⓘ **Cool**— Inverters must be in an area where the fans are not blocked. Do not put the inverter under direct sun light or near a heating source. The ambient temperature should be controlled from 32 to 104°F (preferred temperature of 50-77°F).
- ⓘ **Less dust area**-Do not install the inverter in an environment with high dust, saw dust residue or other particles that may get sucked into the inverter increasing internal temperature.
- ⓘ **Close proximity to battery bank** — prevent excessive voltage drop by keeping the unit close to the battery bank and having a properly sized wire going from the battery bank to the inverter.
- ⓘ **Protection against fire hazard** —There will be some electrical arcing or spark when the inverter connects with the battery. The unit should be away from any flammable material, liquids, gas or any other combustible material. Otherwise it may cause severe consequences.
- ⓘ **Separate compartment from battery** — Do not install the inverter in the same compartment as the battery bank because it could serve as a potential fire hazard..

CAUTION

- ⓘ Cockroaches or other insects may cause damage to the machine, so please take care to keep the machine and the surrounding environment hygienic.

RECOMMENDATION

We recommend mounting the inverter on something stable such as floor, table or stable support to prevent it from bouncing. Mount in a location that can support the weight of the inverters. It is better to fix the product with four screws.

SPECIAL NOTES FOR CHILDREN

- ⊘ NEVER allow children to use the inverter.
- ⊘ NEVER install the unit where it is accessible to children. Keep the unit away from children.
- ⚠ Accessories may cause harm to children, please place all accessories in places that are not easily accessible to children.

2. DC Side Connection Requirements

WARNING

- ⚠ The DOD pure sine wave inverters are suitable for 12V battery bank systems only. Not following the minimum DC requirement will cause irreversible damage to the unit.

CAUTION

- ⚠ Be careful of the positive and negative poles. Reversing the poles might cause permanent damage to the inverter. It will surely blow the internal fuse.

NOTE

- ⚠ The input terminals of the inverters have large capacitors connected to them. Once a positive and negative wire are connected to the terminals, it will complete the circuit, and commence drawing a heavy current momentarily. As a result, there may be a sparking occurring even if the inverter is in the off position. To minimize sparking, it is recommended that the user have the appropriate size wire feeding into the inverters and/or install an external fuse leading into the inverter.

SECURE CONNECTION OF THE INVERTER

- a. **NEGATIVE:** Connect one side of the provided Negative (BLACK) DC cable to the Negative (-) bolt of the inverter, and the other side to the Negative (-) post of the battery.
- b. **POSITIVE:** Connect one side of the provided Positive (RED) DC cable to the Positive (+) bolt of the inverter, and the other side to the Positive (+) post of the battery.
- c. The nuts of the connection posts must be tightened to ensure a good connection.
- d. **SWITCH BUTTON:** Please note that the switch has 3 gears. From top to bottom are on, off and remote.
- e. The inverter will shutdown automatically if connection reversed. Irreversible damage to the machine cannot be excluded which will affect your warranty.

3. Battery Bank Requirements

- ⓘ The battery is for supplying DC input voltage to the inverter. Its rated voltage should be the same as the rated input voltage of the DOD inverter. Any voltage that exceeds the input voltage range of the inverter will cause the inverter to be overloaded and may damage the inverter.
- ⓘ The battery ought to supply enough current for the load. (The load is the amperage or wattage rating of the equipment being powered by the inverter.) A small capacity battery cannot supply enough power for large electrical equipment and it will cause the inverter to be under-voltage.

SIMPLE METHOD

For determining the required battery capacity size is shown below for reference:

1. Determine the Watts (Amps * Volts) of the load
(Each appliance has technical specifications indicating the wattage or voltage and amperage required for operation.)
2. Utilize the formula $Amps = Watts / Volts$
3. Inverter consumption = $Amps * 10\%$
(Due to inverter efficiency 90%, the recommended estimate for the calculation is 10%)
4. Estimated load runtime
(The capacity of the battery depends on the load wattage and runtime. Most loads are not constant, so estimation is essential.)
5. Determine Ah (Ampere-Hour) of the battery

Example: Using 12VDC battery to run a 1200Watts hotplate for 2 hours needs at least 220Ah battery. (10% Inverter consumption)
The calculations are as follows:

Utilize the formula $Amps = Watts / Volts$	$1200 \text{ Watts} / 12 \text{ Volts} = 100 \text{ Amps}$
Inverter consumption	$100 \text{ Amps} \times 10\% = 10 \text{ Amps}$
Load runtime = 2 hours	$(100 \text{ Amps} + 10) \times 2 \text{ hours} = 220 \text{ Ah}$

Conclusion: At least a 220 Ah battery must be selected in order to use the 1200 watts hotplate at 2 hours a day. However, determining the capacity of the battery is also dependent on the battery that is able to handle repeated discharge/charge cycles.

*This is just an example. Actual quantities vary by battery capacity and rates.

*Running wattage may fluctuate. To power the hotplate in the example, must use an inverter of at least 1500 watts.

4. Grounding Requirements

- ⓘ The DOD Pure Sine Wave inverters come equipped with a ground terminal to appropriately ground to earth or to another designated ground. (for example, a metal frame of an RV).
- ⓘ The connections to ground must be tight and against bare metal. Whether using the inverter in a mobile application, such as an RV, or in a building, grounding is highly recommended.

RECOMMENDATION

The recommended wire size for grounding is 14AWG or larger insulated copper strand wire. For more information regarding grounding, users and/or installers must consult with the Local and National Electric Codes(NEC) for more specific grounding regulations and suggestions as they can change per scenario.

■ Operation Safety

Assuming proper battery connection, the inverter is now ready for use.

1. AC Side Operation

- a. Connect electronic devices to electrical socket(s) on inverter. Flip inverter power to ON position. (on AC side)
- b. When finished, switch AC devices off FIRST, then turn off inverter switch

CAUTION

- ⓘ Make sure that the switches of the inverter and appliance power are in OFF position before connection.
- ⓘ When switching off the Inverter, turn off the electronic devices first. Although the Inverter is off, the capacitors will still have a charge, so the DC and AC terminals must be disconnected if altering the circuitry.
- c. Connection of heavy duty
For the appliances with a load more than the limit of AC outlet, please connect to the Hard Terminals Blocks, make sure the ground terminal of inverter connected with ground terminal of appliance.

■ Use Safety

- Do not operate the inverter if under the influence of alcohol or drugs. Read warning labels on prescriptions to determine if your judgement or reflexes are impaired while taking drugs. If there is any doubt, do not operate the inverter.
- People with pacemakers should consult their physician(s) before using this product. Electromagnetic fields in close proximity to a pacemaker could cause interference to or failure of the pacemaker.
- Avoid unintentional starting. Be sure the switch is in the OFF position when not in use and before plugging in any appliance.
- The power inverter will output the same AC power as utility power, please treat the AC outlets as carefully as you would treat an AC outlets at home. Do not put anything besides the appliance into the output terminals. It may cause electric shock or fire. Do not put anything besides the electrical appliance into the output terminal. It may cause electric shock or fire.

■ 5000w Wiring precautions ⚠

When connecting the power cord, be sure to follow the connection method described in the operating instructions. Poor contact with the power line can also lead to inefficient conversion and possibly a blown line at the DC input of the inverter.

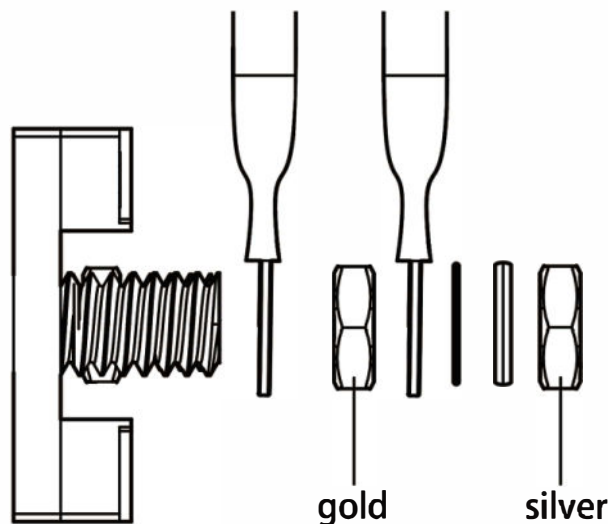

PROTECTION DESCRIPTION

- a. Input under-voltage alarm: When the input DC voltage is lower than 9.8V , the buzzer will whistle intermittently to remind that the inverter will go into the under voltage protection.
- b. Under voltage protection: The inverter will automatically shut down when the input DC voltage is lower than 9.5V. The buzzer will whistle continuously and the green light is off, red light is on. Please turn off the inverter and use it after recharging the battery.
- c. Over voltage protection: The inverter will automatically shut down when the input DC voltage is higher than 16V. The buzzer will whistle continuously and the green light is off, red light is on. Please turn off the inverter and adjust the input voltage to the admissible range.
- d. Overload protection: The inverter will automatically shut down when the load is higher than the rated power. The buzzer will whistle continuously. Turn off the inverter and resume to normal operation after taking away the excessive load.
- e. Short-circuit protection: The AC output will be automatically shut down when short circuited. It will automatically reset after the problem is solved.
- f. Thermal protection: The unit will get hot during operation. If the temperature is higher than 149°F, the inverter will automatically shut down. Then the buzzer will whistle continuously and the green light is off, red light is on. Please turn off the inverter, and continue using it after the temperature goes back to normal naturally. Meanwhile find out the factors causing the fault, such as ventilation, ambient temperature, vent, load power etc. It can avoid similar things from happening again.

■ LCD Display

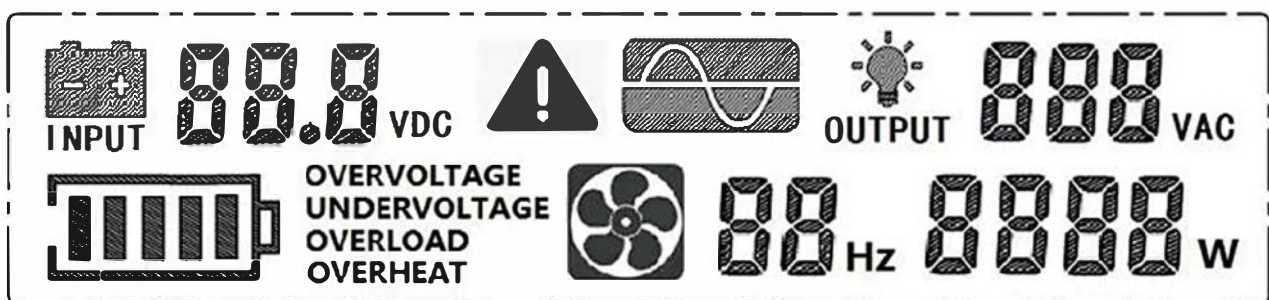

Once the inverter is on protection mode, the following codes will shown:

- a. **UNDERVOLTAGE:** Under-voltage Protection
- b. **OVERVOLTAGE:** Over-voltage Protection
- c. **OVERLOAD:** Over-load or Short-circuit Protection
- d. **OVERHEAT :** Overheating protection

TROUBLESHOOTING TIPS

Problem	Potential Issue	Proper Solution
No output voltage with buzzer sounds continuously	Under-voltage	<ul style="list-style-type: none"> • Charge or replace the battery. • Try to restart the inverter several times due to under-voltage caused by excessive transient current.
	Over-voltage	<ul style="list-style-type: none"> • Do not start the inverter while the battery is charging. • Check the rated voltage of the battery with RMS meter to ensure it is match with the inverter parameters.
	Overload	Reduce the load on the inverter.
	Overheat	<ul style="list-style-type: none"> • Avoid blocking the cooling fan and check for Sufficient ventilation. • Allow the inverter to cool to normal temperature then restart it. •Reduce the load.
Not output voltage nor sounds.	<ol style="list-style-type: none"> 1.The switch is off 2.Poor cable connection 	<ol style="list-style-type: none"> 1. Confirm the switch is on. 2. Inspect terminals and tighten all cables
Unable to run equipment	<ol style="list-style-type: none"> 1.Overload,or the actual running power of the equipment exceeds nominal power. 2.Higher starting power than rated peak power of the equipment (especially with motor). 3. Low battery level or poor battery condition. 	<ol style="list-style-type: none"> 1. Reduce the load,or replace a larger power inverter. 2. Turn on the equipment first,then the power inverter. 3. Ensure the battery was charged or replace a good condition one.



USER MANUAL

POWER INVERTER

Professional supplier with 10+ years experience Creative design excellent appearance Customize your own goods



PURE SINE WAVE ■■■



DOD

NEW ENERGY

